

# Flow sensor for liquid media type 230

Flow range  
1.8 ... 150 l/min

Nominal diameters  
DN 10 / 15 / 20 / 25

Temperature measurement  
-40 ... +125 °C



The flow sensor type 230 is based on the Kármán vortex trail. You can choose between various versions as integrated temperature measurement.

The type 230 has a rugged construction of red brass. With no moving parts the flow sensor is not sensitive to debris, has marginal pressure loss and high accuracy.

- Flow measuring with voltage, current or frequency output
- Temperature non-sensitive measuring principle
- Excellent media resistance (measuring element not in contact with the media)
- CE conformity
- Wide application temperature range
- Marginal loss of pressure
- Measuring element not sensitive to debris
- Zinc free red brass housing
- Drinking water approval

## Technical Overview

### Flow measurement

Measuring principle	Vortex	Piezoelectric sensor element
Measuring range		1.8 ... 150 l/min
Nominal diameters		DN 10 / 15 / 20 / 25
Accuracy at < 50% fs (water)		< 1% fs
Accuracy at > 50% fs (water)		< 2% measuring value
Response time	Immediately Therefore suitable for spigot use.	Signal delay < 100 ms
		Response time < 5 ms
		Frequency output
		Signal delay < 2 s
		Analogue output
		Response time < 500 ms

### Temperature measurement

Measuring principle	Resistance	PT1000
	Measuring range	-40 ... +125 °C
PT1000	Accuracy	class B DIN EN 60751
		@ T = 0 °C
		@ T ≠ 0 °C
		± 0.3 K
		± 0.3 K ± 0.005 * T
	Measuring range	-25 ... +125 °C
0 ... 10 V	Accuracy	± 0.5 K ± 0.005 * T
	Calculation temperature	$T (^{\circ}\text{C}) = \pm 150 \frac{\text{V}}{10 \text{ V}} * U_{\text{OUT},T} - 25 \text{ }^{\circ}\text{C}$
Temperature influences	Self-heating at temperature sensor	1 K/mW
	Conduction resistance to connector	0.8 Ohm

### Operating conditions

Medium	Suitable for heating circuit water with the usual additives Drinking water	Other medium on request
temperature	Media	≤ +125 °C
	Ambient	-15 ... +85 °C
	Storage	-30 ... +85 °C
Max. pressure and medium temperature	(for lifetime)	12 bar at +40 °C
	(for lifetime)	6 bar at +100 °C
	(for 600 hours)	4 bar at +125 °C
	(for 2 hours)	4 bar at +140 °C
	(max. test pressure)	18 bar at +40 °C
Cavitation	The following equation is valid to prevent cavitation:	$P_{\text{abs outlet}} / P_{\text{difference}} > 5.5$

### Materials in contact with medium (FDA-conform)

Sensor paddle	ETFE
Case	Red brass / PA6T/6I (40% GF)
Sealing material	EPDM (perox.)

### Electrical overview

		Frequency output	Voltage output	Current output
Power supply	$U_{\text{IN}}$	4.75 ... 33 VDC	11.5 ... 33 VDC	8 ... 33 VDC
Output	Frequency square pulse signal $U_{\text{OUT},Q,\text{frequency}}$	< 0.5 ... > $U_{\text{IN}} - 0.5 \text{ V}$	–	–
Flow (Q)	Analogue signal	$U_{\text{OUT},Q}$ oder $I_{\text{OUT}}$	0 ... 10 V	4 ... 20 mA
Output	Resistant signal	$R_{\text{OUT PT1000}}$	PT1000 class B DIN EN 60751	–
temperature (T)	Voltage signal	$U_{\text{OUT},T}$	0 ... 10 V	–
Electrical connection and protection class		M12x1 (IP 65)	M12x1 (IP 65)	M12x1 (IP 65)
Load against GND or IN		< 1 mA / < 100 nF	< 6 mA / < 100 nF <sup>1)</sup>	< ( $U_{\text{IN}} - 8 \text{ V}$ ) / 20 mA
Current consumption load free ( $I_{\text{IN}}$ )		< 2mA	< 5 mA	–

### Weight

DN 10	outside thread L	~ 230 g
	outside thread A	~ 240 g
DN 15	outside thread L	~ 310 g
	outside thread A	~ 340 g
DN 20	outside thread L	~ 440 g
	outside thread A	~ 510 g
DN 25	outside thread L	~ 600 g

### Test / Admissions

Drinking water approval	
Electromagnetic compatibility	CE-conform acc. to EN 61326-2-3

### Packaging

Single packaging

## Minimum life span on high flow rate and high temperature

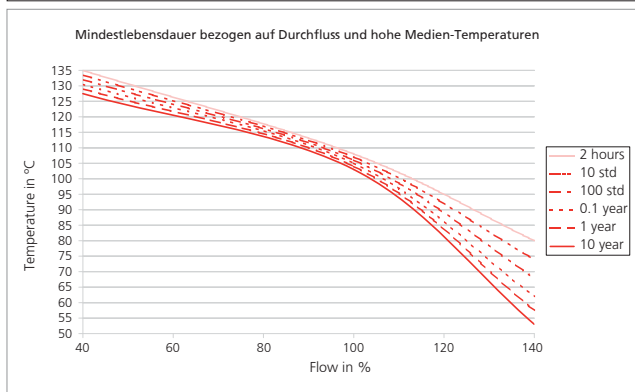

<sup>1)</sup> against GND only

## Nominal diameters dependent variables

Nominal diameters	Connection	Measuring range	Quantity per puls	Flow range	Characteristic line frequency output	Frequency range	Characteristic line voltage output	Characteristic line current output	Pressure drop <sup>1), 2)</sup>
DN 10	Outside thread heavy	1.8 ... 32 l/min	1.378 ml	0.265 ... 4.716 m/s	0.0837 * f - 0.2	24 ... 385 Hz	Q = 3.2 * U <sub>OUT,Q</sub>	Q = 2.000 * (I - 4 mA)	22.50 * Q <sup>2</sup>
DN 10	Outside thread heavy	2.0 ... 40 l/min	1.381 ml	0.295 ... 5.895 m/s	0.0837 * f - 0.2	26 ... 480 Hz	Q = 4.0 * U <sub>OUT,Q</sub>	Q = 2.500 * (I - 4 mA)	22.50 * Q <sup>2</sup>
DN 15	Outside thread small	3.5 ... 50 l/min	2.998 ml	0.290 ... 4.145 m/s	0.1813 * f - 0.2	20 ... 277 Hz	Q = 5.0 * U <sub>OUT,Q</sub>	Q = 3.125 * (I - 4 mA)	6.70 * Q <sup>2</sup>
	Outside thread heavy		2.975 ml		0.1799 * f - 0.2	21 ... 279 Hz			
DN 20	Outside thread small	5.0 ... 85 l/min	6.109 ml	0.265 ... 4.509 m/s	0.3691 * f - 0.3	14 ... 231 Hz	Q = 8.5 * U <sub>OUT,Q</sub>	Q = 5.313 * (I - 4 mA)	2.50 * Q <sup>2</sup>
	Outside thread heavy		6.057 ml		0.3660 * f - 0.3	14 ... 233 Hz			
DN 25	Outside thread small	9.0 ... 150 l/min	12.114 ml	0.283 ... 4.709 m/s	0.7288 * f - 0.2	13 ... 206 Hz	Q = 15 * U <sub>OUT,Q</sub>	Q = 9.375 * (I - 4 mA)	0.92 * Q <sup>2</sup>
	Outside thread heavy		12.143 ml		0.7305 * f - 0.2				

## Order code selection table

230. X X X X X X X X

Version	Flow		9					4	
	Flow and temperature (PT1000)		8					5	
	Flow and temperature (0 ... 10 V)		6					5	
Nominal diameters and flow range	DN 10 1.8 ... 32 l/min.			1	0				L
	DN 10 2.0 ... 40 l/min.			1	1				L
	DN 15 3.5 ... 50 l/min.			1	5				
	DN 20 5.0 ... 85 l/min.			2	0				
	DN 25 9.0 ... 150 l/min.			2	5				
Output and power supply	Frequency output (Square pulse signal)	4.75 ... 33 VDC	8,9					2	
	Analogue signal 0 ... 10 V	11.5 ... 33 VDC						3	
	Analogue signal 4 ... 20 mA	8 ... 33 VDC	8,9					4	
Electrical connection	Connector M12x1 2- or 3-pole (condensation protection)		9					4	
	Connector M12x1 4- or 5-pole (condensation protection)		8,6					5	
Sealing material	EPDM Ethylene propylene rubber (peroxidically cross-linked)								
Red brass body	Red brass armature outside thread A (see dimension diagram)								
	Red brass armature outside thread L (see dimension diagram)								

## Accessories<sup>3)</sup>

				Order number
Straight-wire box for connector M12x1 with cable	3-pole	200 cm		114605
Corner-wire box for connector M12x1 with cable	3-pole	200 cm		114604
Straight-wire box for connector M12x1 with cable	5-pole	200 cm	(with temperature)	114564
Corner-wire box for connector M12x1 with cable	5-pole	200 cm	(with temperature)	114563
Straight-wire box for connector M12x1 screwing terminal				115024

## Dimension diagram DN 10, 15, 20, 25

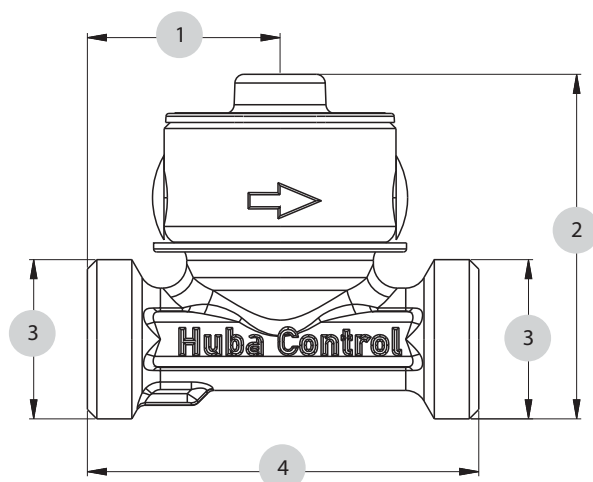

		1	2	3	4
DN10	L	32	57.22	G ¾	65
DN15	A	40	59.22	G ¾	75
DN15	L	40	62.65	G 1	75
DN20	A	49	64.62	G 1	86
DN20	L	49	68.95	G 1¼	86
DN25	A	70	71.45	G 1¼	109
DN25	L	70	74.40	G 1½	109

<sup>1)</sup> incl. 3xDi inlet and outlet side

<sup>2)</sup> Pv in Pa; Q in l/min

<sup>3)</sup> Accessories supplied loose

## Tube mounting instructions

Consider the following to ensure the correct function of the sensor.

- Only diameter changes from large to small are allowed.
- Avoid repeated elbows in the same level at entryside

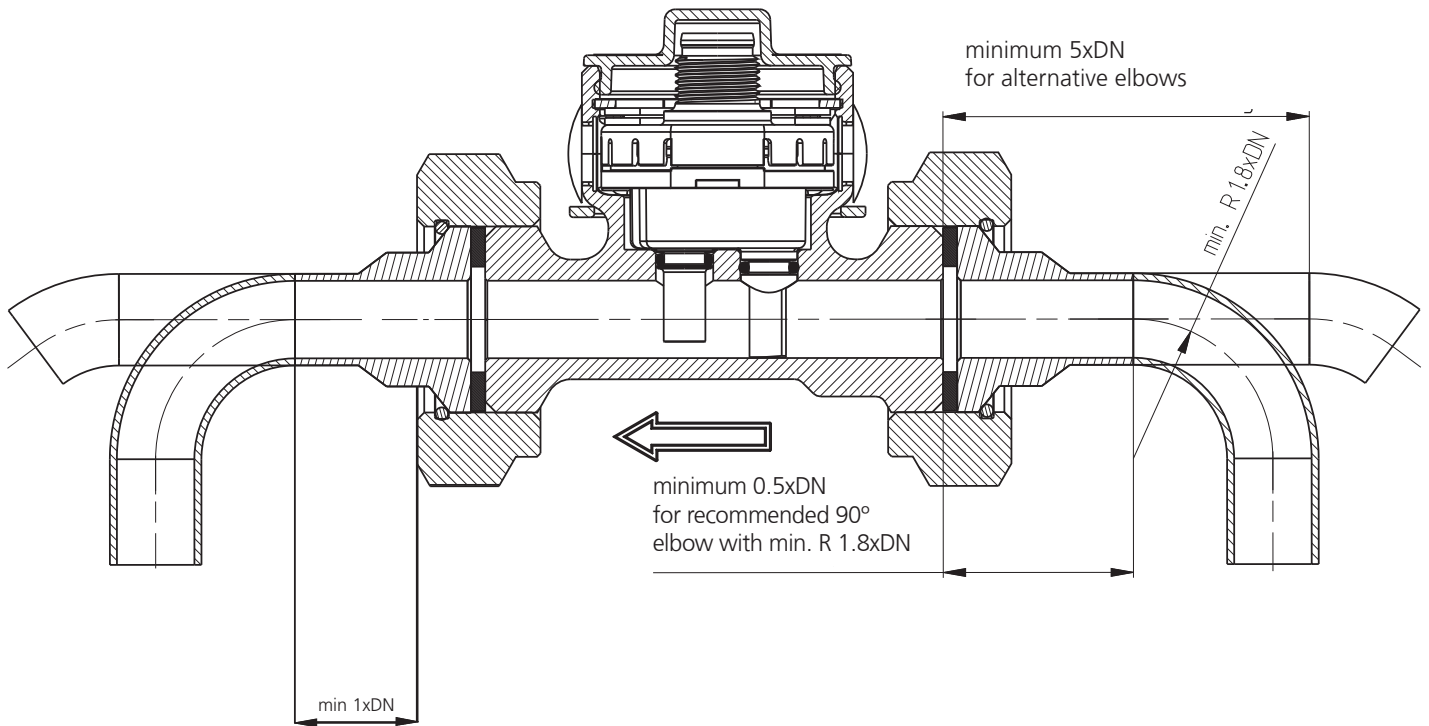

## Electrical connection

Connector M12x1 without temperature measurement

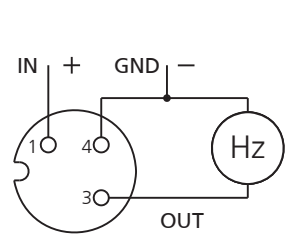

Frequency output

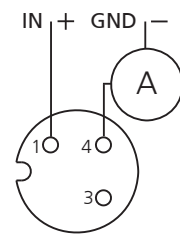

current output

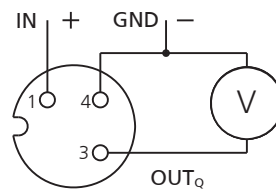

voltage output

Pin	Colour
1	brown
3	blue
4	black
1	brown
2	white
3	blue
4	black
5	gray

Connector M12x1 with temperature measurement

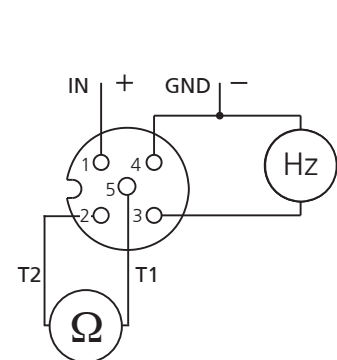

Frequency output with PT1000

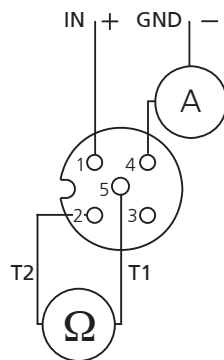

current output with PT1000

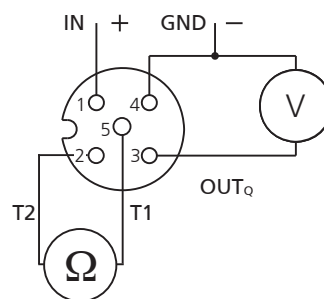

voltage output with PT1000

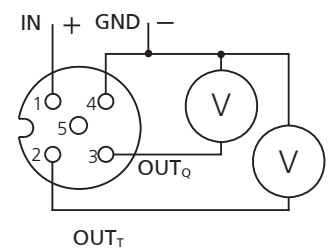

voltage output with temperature output 0 ... 10 V

With the following definitions we are able to correct the influence of media with higher viscosity than water (= media viscosity > 1.8 cSt) in order to reach a measuring accuracy of 3% fs in the range of 1.8 - 4 cSt and of 4% in the range of 4 - 14 cSt ( $\nu$  = viscosity in cSt).

## Definition of viscosity of glycol-water-compound

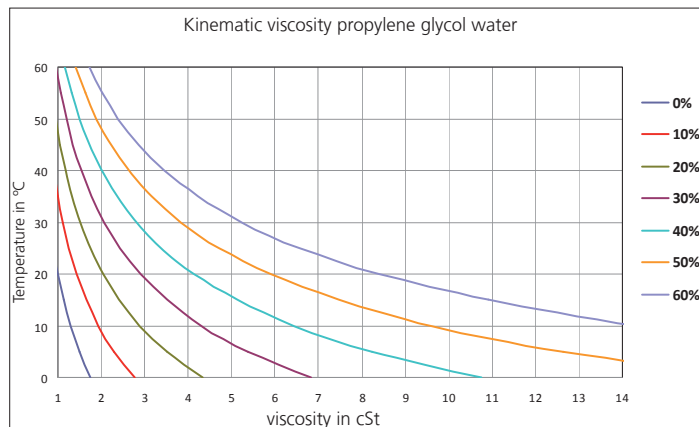
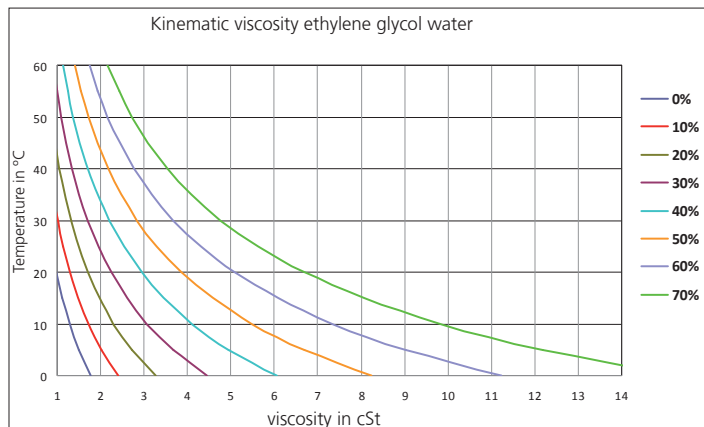

## Definition of respond threshold $Q_{min}$

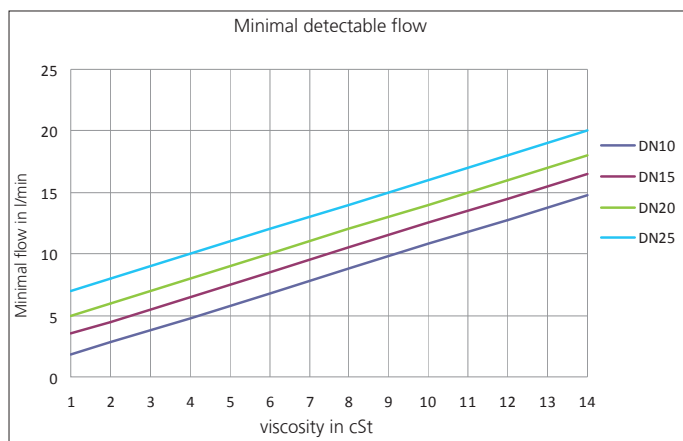

## Definition of characteristic line formula $Q = k * f - Q_0$

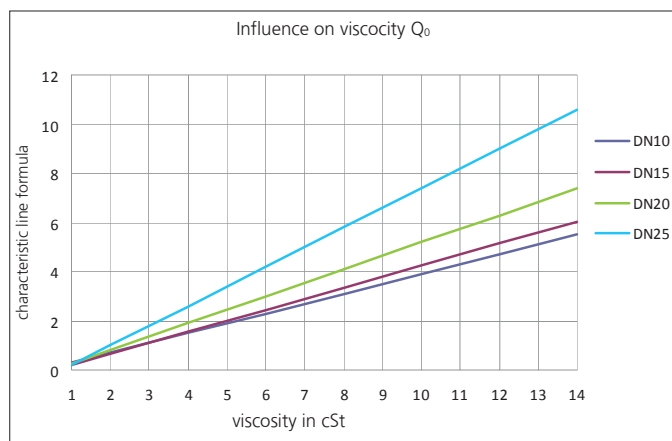

### Formula respond threshold $Q_{min}$ in l/min

< DN 10 not possible

DN 10:  $Q_{min} = \nu + 0.8$

DN 15:  $Q_{min} = \nu + 2.5$

DN 20:  $Q_{min} = \nu + 4.0$

DN 25:  $Q_{min} = \nu + 6.0$

### Formula characteristic line for $Q \geq Q_{min}$ in l/min

< DN 10 not possible

Frequency output:

DN10:  $Q = 0.0832 * f - 0.40\nu + 0.20$

DN15:  $Q = 0.1843 * f - 0.45\nu + 0.25$

DN20:  $Q = 0.3754 * f - 0.55\nu + 0.25$

DN25:  $Q = 0.7467 * f - 0.80\nu + 0.60$

Voltage output 0 ... 10 V

DN10:  $Q = 3.2 * U_{Out} - 0.40\nu + 0.40$

DN15:  $Q = 5.0 * U_{Out} - 0.45\nu + 0.45$

DN20:  $Q = 8.5 * U_{Out} - 0.55\nu + 0.55$

DN25:  $Q = 15.0 * U_{Out} - 0.80\nu + 0.80$

Current output 4 ... 20 mA (I in mA)

DN10:  $Q = 2.000 * (I - 4 \text{ mA}) - 0.40\nu + 0.40$

DN15:  $Q = 3.125 * (I - 4 \text{ mA}) - 0.45\nu + 0.45$

DN20:  $Q = 5.313 * (I - 4 \text{ mA}) - 0.55\nu + 0.55$

DN25:  $Q = 9.375 * (I - 4 \text{ mA}) - 0.80\nu + 0.80$

Huba Control AG  
Headquarters

Industriestrasse 17  
5436 Würenlos  
Telefon +41 (0) 56 436 82 00  
Telefax +41 (0) 56 436 82 82  
info.ch@hubacontrol.com

Huba Control AG  
Niederlassung Deutschland

Schlattgrabenstrasse 24  
72141 Walddorfhäslach  
Telefon +49 (0) 7127 23 93 00  
Telefax +49 (0) 7127 23 93 20  
info.de@hubacontrol.com

Huba Control SA  
Succursale France

Rue Lavoisier  
Technopôle Forbach-Sud  
57602 Forbach Cedex  
Téléphone +33 (0) 387 847 300  
Télécopieur +33 (0) 387 847 301  
info.fr@hubacontrol.com

Huba Control AG  
Vestiging Nederland

Hamseweg 20A  
3828 AD Hoogland  
Telefoon +31 (0) 33 433 03 66  
Telefax +31 (0) 33 433 03 77  
info.nl@hubacontrol.com

Huba Control AG  
Branch Office United Kingdom

Unit 13 Berkshire House  
County Park Business Centre  
Shrivenham Road  
Swindon - Wiltshire SN1 2NR  
Phone +44 (0) 1993 776667  
Fax +44 (0) 1993 776671  
info.uk@hubacontrol.com